



PC-2071

Tyler CI Soil Pipe

Twenty Eighth Edition, February, 2007



www.tylerpipe.com

Tyler Pipe/Soil Division • Box 2027 • Tyler, Texas 75710 • (800) 527-8478



HOW TO ORDER

Guide To Ordering

- To avoid errors, specify UPC numbers.
- When selecting regular fittings, size of openings appear in this order:
 - Main
 - Branch or branches
- When selecting reducing/increasing fittings, size appears as illustrated:

Hub & Spigot:

- Spigot of Main
- Hub of Main
- Branch (Branches) or Side Openings
- Length

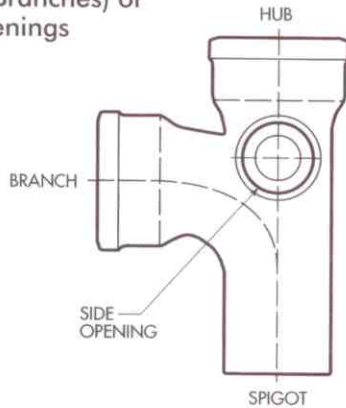

No Hub:

- Bottom Outlet
- Top Inlet
- Branch (Branches) or Side Openings
- Length

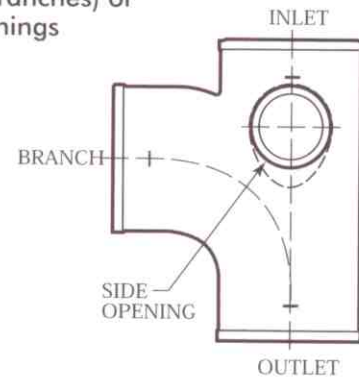

RH (Right Hand) Fittings Illustrated

- When selecting long fittings, long bends are measured from the spigot (outlet) to the centerline of the hub (inlet); long branch fittings are measured from the spigot (outlet) to the base of the hub (inlet).
- To specify right or left side openings, position fittings as follows and read left or right...
 - Bends, face open hub (inlet) with spigot (outlet) down.
 - Branch fittings, face open hub (inlet) of main with branch down.
- All pipe and fittings are furnished coated.

STANDARDS & SPECIFICATIONS

Piping to be installed for the various services shall be as specified or in accordance with local plumbing codes:

CURRENT STANDARDS

¶ NO-HUB® Cast Iron Soil Pipe and Fittings:

CISPI 301 (Cast Iron Soil Pipe Institute)
 ASTM A 888 (American Society for Testing and Materials)

¶ NO-HUB® Couplings

CISPI 310 (Cast Iron Soil Pipe Institute)
 ASTM C 1277 (American Society for Testing and Materials)
 ASTM C 1540 (American Society for Testing and Materials)

SV Hub and Spigot Cast Iron Soil Pipe and Fittings:

ASTM A 74 (American Society for Testing and Materials)

Hub & Spigot Gaskets:

ASTM C 564 (American Society for Testing and Materials)



NO-HUB ASA Group 022 PIPE & COUPLINGS

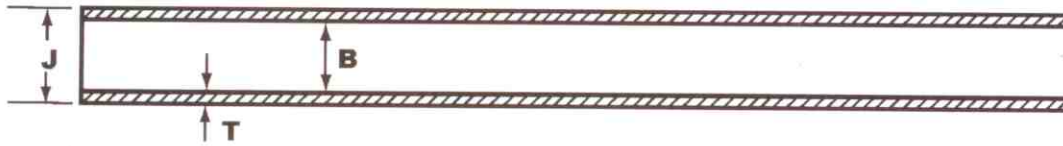

NO-HUB PIPE, TEN-FOOT LAYING LENGTH

Ship Code	UPCode 670610	Dia.	Wt. per 10' lbs.	Per Bundle Pieces	Wt. lbs.
S	006763	1½	25	54	1350
S	006770	2	36	54	1955
S	006787	3	52	36	1855
S	006794	4	74	27	2013
S	006800	5	94	24	2256
S	006817	6	110	18	1998
S	006824	8	180	15	2718
S	006831	10	258	8	2084
S	376583	12	355	6	2130
S	376590	15	515	4	2060

*Note: Weights approximate, for shipping purposes only.

DIMENSIONS AND TOLERANCES

Size	Hubless Pipe Barrels		
	B Inside Diameter	J Outside Diameter	T Thickness Norm. Min.
1½	1.50±.09	1.90±.06	.16 .13
2	1.96±.09	2.35±.09	.16 .13
3	2.96±.09	3.35±.09	.16 .13
4	3.94±.09	4.38+.09-.05	.19 .15
5	4.94±.09	5.30+.09-.05	.19 .15
6	5.94±.09	6.30+.09-.05	.19 .15
8	7.94±.13	8.38+13-.09	.23 .17
10*	10.00±.13	10.56±.09	.28 .22
12*	11.94±.13	12.50±.13	.28 .22
15*	15.11±.13	15.83±.13	.36 .30

*O.D. Barrel out of round tolerance of ±.04 is permitted.

"Tyler Pipe Company strongly recommends that its hubless cast iron pipe and fittings be joined with shielded couplings manufactured in accordance with CISPI 310. The use of unshielded couplings or any coupling not meeting the above specifications will void the product warranty"



1½" - 4"

5" - 10"

12" & 15"

NO-HUB COUPLING ASSEMBLY

Ship Code	UPCode 670610	Size & Description	Carton		Pallet	
			Quantity	Wt.	Quantity	Wt.
S	006206	1½	100	20	3600	720
S	006213	2x1½	100	30	3600	1080
S	006220	2	100	20	3600	720
S	006237	3x2	100	60	2400	1440
S	006244	3	100	40	2400	960
S	006251	4x3	60	48	1440	1152
S	006268	4	100	50	1600	800
S	006275	5	20	16	480	384
S	006282	6	25	25	450	450
S	006299	8	10	18	200	360
S	006305	10	10	21	120	252
S	376569	12*	2	7	48	168
S	376576	15*	2	9	48	216

*ANACO Couplings

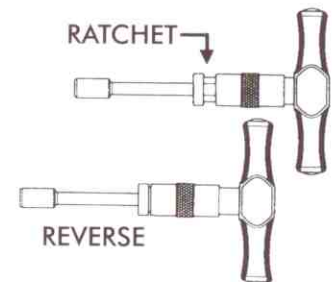

TORQUE WRENCH 60-inch Pounds

Ship Code	UPCode 670610	Wt.
S	006558	2.0



NO-HUB ASA Group 022 BENDS & SWEEPS

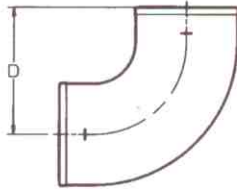

QUARTER BEND

Ship Code	UPCode 670610	Size	D	Wt.
S	006848	1½	4¼	1.9
S	006855	2	4½	2.8
S	006862	3	5	4.9
S	006879	4	5½	7.7
S	006886	5	6½	9.7
S	006893	6	7	13.0
S	006909	8	8½	26.2

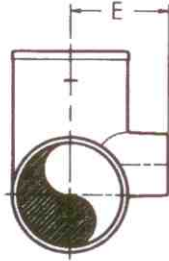

QUARTER BEND w/2" Side Opening

Ship Code	UPCode 670610	Size	D	D'	E	Wt.
S	006923	3	5	4	3¼	4.4
S	006930	4	5½	4⅝	3¾	7.5

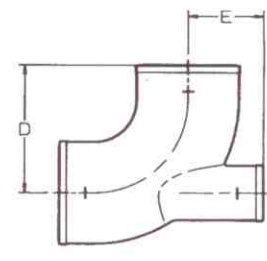
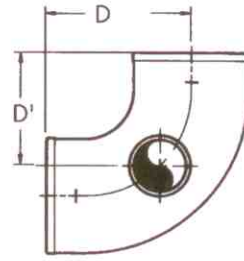

QUARTER BEND w/ 2" Heel Opening

Ship Code	UPCode 670610	Size	D	E	Wt.
S	006947	3	5	2⅞	4.4
S	006954	4	5½	3¼	6.5

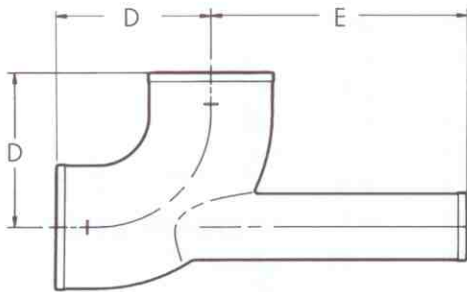

QUARTER BEND EXTENDED LOW HEEL INLET

Ship Code	UPCode 670610	Size	D	E	Wt.
S	011019	3x2	5	10½	7.8

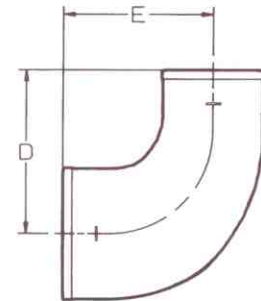

REDUCING QUARTER BEND (FLA. STYLE)

Ship Code	UPCode 670610	Size	D	E	Wt.
S	006916	4x3	5½	5	5.0

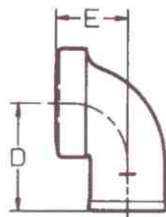

TAP SHORT QUARTER BEND

Ship Code	UPCode 670610	Size	D	E	Wt.
S	006961	1½x1½	3	2	1.5
S	006978	2x1¼	3¼	2¼	1.5
S	006985	2x1½	3¼	2¼	1.5
S	006992	2x2	3¼	2¼	2.6

SHIPPING CODE
S = From Stock
N = Non-Stock; Check in advance for availability.

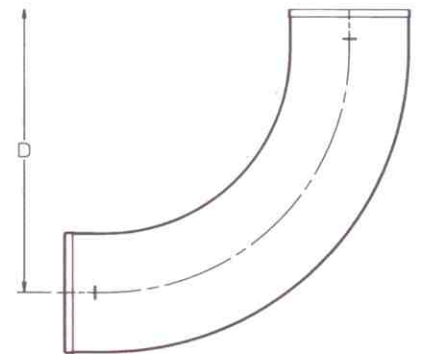

LONG SWEEP

Ship Code	UPCode 670610	Size	D	Wt.
S	007180	1½	9¼	4.1
S	007197	2	9½	6.0
S	007203	3	10	8.5
N	007258	4x3	10½	11.5
S	007210	4	10½	13.4
S	007227	5	11½	17.0
S	007234	6	12	20.9

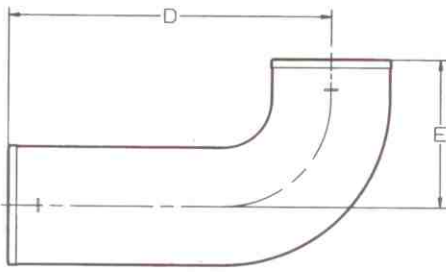

LONG QUARTER BEND

Ship Code	UPCode	Size-Lgth	D	E	Wt.
S	007067	2-12	12	4½	5.0
S	007043	2-14	14	4½	5.6
S	007050	2-16	16	4½	6.3
S	007074	2-18	18	4½	6.7
N	062875	2-24	24	4½	10.7
S	007081	3-12	12	5	7.3
S	007098	3-18	18	5	10.4
S	007104	4-12	12	5½	10.2

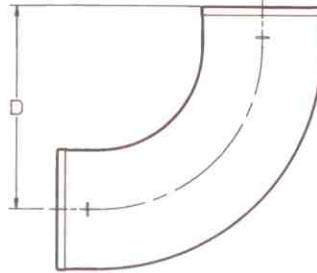

SHORT SWEEP

Ship Code	UPCode	Size	D	Wt.
S	007111	2	6½	4.2
S	007128	3	7	6.2
S	007135	4	7½	9.6
S	007142	5	8½	12.8
S	007159	6	9	15.9
S	007166	8	10½	30.0
S	007173	10	12	55.4
S	376651	12	13¼	70.0
S	376668	15	14¾	130.0

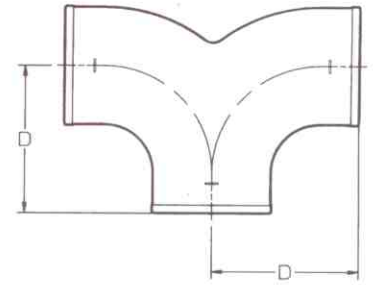

DOUBLE QUARTER BEND

Ship Code	UPCode	Size	D	Wt.
S	007012	2	4½	3.6
S	007029	3	5	6.0
S	007036	4	5½	9.8

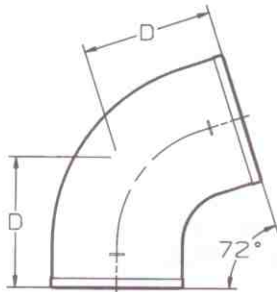

FIFTH BEND

Ship Code	UPCode	Size	D	Wt.
S	007265	2	3 11/16	2.0
S	007272	3	4 1/16	3.5
S	007289	4	4 7/16	5.5

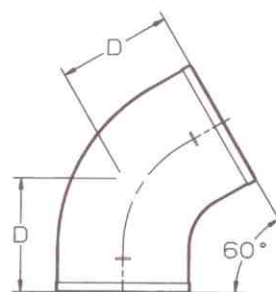

SIXTH BEND

Ship Code	UPCode	Size	D	Wt.
S	007296	2	3½	2.0
S	007302	3	3½	3.0
S	007319	4	3 13/16	5.1

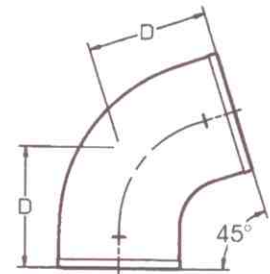

EIGHTH BEND

Ship Code	UPCode	Size	D	Wt.
S	007326	1½	2 5/8	1.1
S	007333	2	2¾	2.1
S	007340	3	3	3.3
S	007357	4	3 1/8	4.4
S	007364	5	3 3/16	6.8
S	007371	6	4 1/16	8.5
S	007388	8	5	15.0
S	007395	10	5 5/16	30.7
S	376491	12	6 9/16	39.0
S	376675	15	7 3/16	70.0

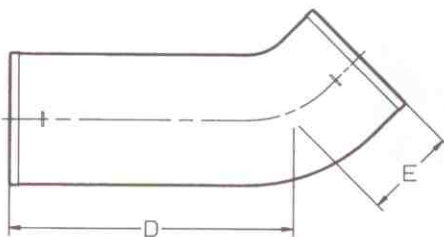

LONG EIGHTH BEND

Ship Code	UPCode	Size - Length	D	E	Wt.
N	382652	2-6	6	3	2.4
S	007401	2-12	12	2¾	4.9
S	007432	2-16	16	2¾	5.9
S	007456	2-18	18	2¾	6.5
S	007425	3-12	12	3	6.9
S	007449	4-12	12	3 1/8	0.4

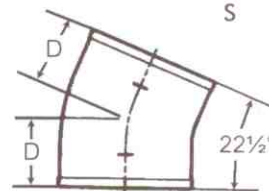

SIXTEENTH BEND

Ship Code	UPCode	Size	D	Wt.
S	007487	1½	2 1/8	1.0
S	007494	2	2 1/8	1.3
S	007500	3	2¼	2.4
S	007517	4	2 5/16	3.8
S	007524	5	2 7/8	5.4
S	007531	6	3	7.3
S	007548	8	3¾	12.0



NO-HUB ASA Group 022 TEES

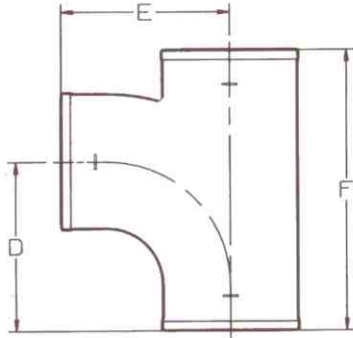

SAN TEE

Ship Code	UPCode 670610	Size	D	F	E	Wt.
S	007555	1 1/2	4 1/4	6 1/2	4 1/4	2.3
S	007562	2x1 1/2	4 1/4	6 5/8	4 1/2	3.0
S	007579	2	4 1/2	6 7/8	4 1/2	3.4
S	007586	3x1 1/2	4 1/4	6 1/2	5	3.2
S	007593	3x2	4 1/2	6 7/8	5	4.9
S	007609	3	5	8	5	5.9
S	007616	4x2	4 1/2	6 7/8	5 1/2	6.6
S	007623	4x3	5	8	5 1/2	8.3
S	007630	4	5 1/2	9 1/8	5 1/2	9.6
S	007647	5x2	5	8 1/2	6 1/2	8.7
S	007654	5x3	5 1/2	9 5/16	6	9.8
S	007661	5x4	6	10 13/32	6	11.8
S	007678	5	6 1/2	11 7/16	6 1/2	12.6
S	007685	6x2	5	8 3/16	6 1/2	11.0
S	007715	6x3	5 1/2	9 3/16	6 1/2	11.5
S	007692	6x4	6	10 1/16	6 1/2	13.0
S	382669	6x5	6 1/2	11 1/2	7	17.4
S	007708	6	7	12 1/2	7	15.0
S	007722	8x3	6	10 3/8	7 1/2	17.0
S	007739	8x4	6 1/2	11 1/2	7 1/2	19.5
S	007746	8x5	7	12 1/2	8	25.0
S	007753	8x6	7 1/2	13 1/2	8	25.0
S	007760	8	8 1/2	15 1/2	8 1/2	33.3

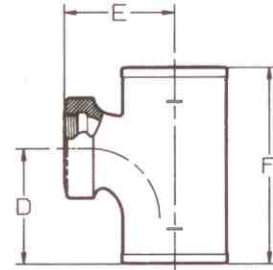

SAN TAP TEE

Ship Code	UPCode 670610	Size x Tap	D	E	F	Wt.
S	007968	1 1/2 x 1 1/4	3 1/4	2 9/16	5 11/16	2.3
S	007975	1 1/2	3 1/4	2 9/16	5 11/16	2.1
S	007982	2x1 1/4	3 1/4	2 13/16	5 11/16	2.4
S	007999	2x1 1/2	3 1/4	2 13/16	5 11/16	2.5
S	008002	2	3 3/4	3 1/16	6 3/8	2.9
S	008019	3x1 1/4	3 1/4	3 5/16	5 11/16	3.5
S	008026	3x1 1/2	3 1/4	3 5/16	5 11/16	3.7
S	008033	3x2	3 3/4	3 9/16	6 3/8	4.5
S	008040	3	4 7/8	4 3/16	8	7.4
S	008057	4x1 1/4	3 1/4	3 13/16	5 11/16	5.0
S	008064	4x1 1/2	3 1/4	3 13/16	5 11/16	4.8
S	008071	4x2	3 3/4	4 1/16	6 3/8	5.4
S	383277	4x3	4 1/2	4 3/8	8	7.0
S	008095	5x1 1/2	3 3/4	4 5/16	6 11/16	8.0
S	008101	5x2	4 1/4	4 9/16	6 11/16	7.1
S	008125	6x1 1/2	3 3/4	5 3/16	6 11/16	8.5
S	008132	6x2	3 3/4	5 3/16	6 11/16	8.3

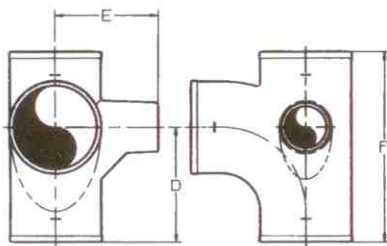

**SAN TEE
(w/2" 90° Side Opening on Center)**

Ship Code	UPCode 670610	Size	Opening	E	F	D	Wt.
S	007777	3	LH	4 7/16	8	5	5.0
S	007791	3	RH	4 7/16	8	5	5.0
S	007784	4	LH	4 15/16	9 1/8	5 1/2	9.2
S	007807	4	RH	4 15/16	9 1/8	5 1/2	9.2

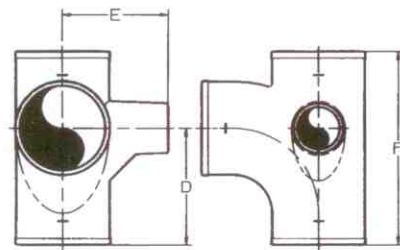

**SAN TEE
(w/2" 90° Side Opening Above Center)
New Orleans Code**

Ship Code	UPCode 670610	Size Opening	C	D	E	F	G	Wt.
S	007838	3 LH	4 1/2	6	5	8 1/2	5	6.3
S	007852	3 RH	4 1/2	6	5	8 1/2	5	6.3
S	007876	3 R&L	4 1/2	6	5	8 1/2	5	7.3
S	007845	4 LH	5	6 1/2	5 1/2	9 1/8	5 1/2	9.5
S	007869	4 RH	5	6 1/2	5 1/2	9 1/8	5 1/2	9.5
S	007883	4 R&L	5	6 1/2	5 1/2	9 1/8	5 1/2	10.0

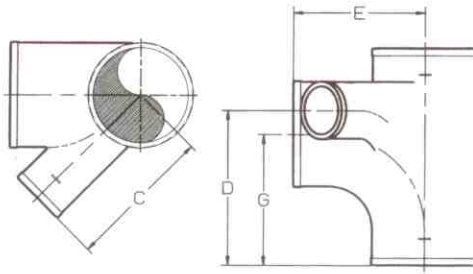

SAN TEE
(w/2" 45° Side Opening Above Center)
New Orleans Code

Ship Code	UPCode 670610	Size	Opening	C	D	E	F	G	Wt.
S	007913	3	LH	5 $\frac{3}{8}$	6	5	8 $\frac{1}{2}$	5	6.0
S	007937	3	RH	5 $\frac{3}{8}$	6	5	8 $\frac{1}{2}$	5	6.0
N	387831	3	RL	5 $\frac{3}{8}$	6	5	8 $\frac{3}{4}$	5	7.5
S	007920	4	LH	6 $\frac{1}{8}$	6 $\frac{1}{2}$	5 $\frac{1}{2}$	9 $\frac{1}{8}$	5 $\frac{1}{2}$	9.3
S	007944	4	RH	6 $\frac{1}{8}$	6 $\frac{1}{2}$	5 $\frac{1}{2}$	9 $\frac{1}{8}$	5 $\frac{1}{2}$	9.3

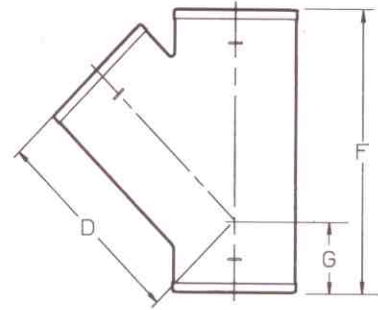

WYE

Ship Code	UPCode 670610	Size	D	F	G	Wt.
S	008200	1 $\frac{1}{2}$	4	6	2	2.0
S	008217	2	4 $\frac{5}{8}$	6 $\frac{5}{8}$	2	3.6
S	383291	3x1 $\frac{1}{2}$	4 $\frac{5}{8}$	6 $\frac{5}{8}$	2	3.0
S	008224	3x2	5 $\frac{1}{16}$	6 $\frac{5}{8}$	1 $\frac{1}{2}$	4.3
S	008231	3	5 $\frac{3}{4}$	8	2 $\frac{1}{4}$	6.5
S	008248	4x2	6	6 $\frac{5}{8}$	1	5.8
S	008255	4x3	6 $\frac{1}{2}$	8	1 $\frac{11}{16}$	9.0
S	008262	4	7 $\frac{1}{16}$	9 $\frac{1}{2}$	2 $\frac{7}{16}$	10.3
S	008279	5x2	7 $\frac{1}{2}$	8 $\frac{1}{16}$	1 $\frac{5}{16}$	7.2
S	008286	5x3	8	9 $\frac{11}{16}$	1 $\frac{11}{16}$	10.5
S	008293	5x4	8 $\frac{1}{2}$	11 $\frac{3}{16}$	2 $\frac{7}{16}$	12.6
S	008309	5	9 $\frac{1}{2}$	12 $\frac{5}{8}$	3 $\frac{3}{8}$	14.5
S	008316	6x2	8 $\frac{1}{4}$	8 $\frac{5}{16}$	$\frac{1}{2}$	9.5
S	008323	6x3	8 $\frac{3}{4}$	9 $\frac{3}{4}$	1 $\frac{1}{4}$	11.0
S	008330	6x4	9 $\frac{1}{4}$	11 $\frac{3}{16}$	1 $\frac{15}{16}$	16.0
S	008347	6x5	10 $\frac{1}{4}$	12 $\frac{1}{2}$	2 $\frac{7}{16}$	17.7
S	008354	6	10 $\frac{3}{4}$	14 $\frac{1}{16}$	3 $\frac{5}{16}$	21.0
S	008361	8x2	9 $\frac{3}{8}$	8 $\frac{1}{2}$	$\frac{7}{16}$	15.0
S	008378	8x3	9 $\frac{13}{16}$	9 $\frac{15}{16}$	$\frac{1}{8}$	17.5
S	008385	8x4	10 $\frac{3}{8}$	11 $\frac{7}{16}$	1 $\frac{5}{16}$	21.8
S	008392	8x5	11 $\frac{3}{8}$	12 $\frac{13}{16}$	1 $\frac{5}{8}$	25.5
S	008408	8x6	11 $\frac{13}{16}$	14 $\frac{3}{16}$	2 $\frac{15}{16}$	28.3
S	008415	8	13 $\frac{3}{8}$	17 $\frac{7}{8}$	3 $\frac{3}{4}$	39.3
S	008422	10x4	11 $\frac{11}{16}$	12 $\frac{5}{8}$	$\frac{3}{4}$	37.0
S	008439	10x6	13 $\frac{3}{8}$	15 $\frac{7}{16}$	2 $\frac{3}{16}$	48.0
S	008446	10x8	14 $\frac{11}{16}$	18 $\frac{3}{8}$	3 $\frac{5}{8}$	57.0
S	008453	10	16 $\frac{1}{2}$	21 $\frac{1}{2}$	5 $\frac{1}{16}$	73.0
S	376736	12	19 $\frac{3}{4}$	25 $\frac{1}{2}$	5 $\frac{3}{4}$	112.0
S	376644	15	23 $\frac{1}{4}$	30	6 $\frac{3}{4}$	193.0

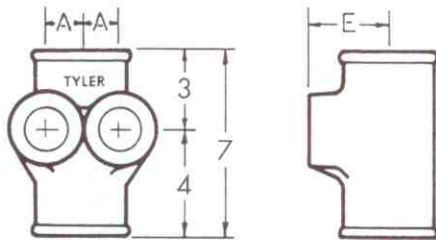

HORIZONTAL TWIN TAP TEE

Ship Code	UPCode 670610	Size	A	E	Wt.
S	008170	3x1 $\frac{1}{2}$	1 $\frac{3}{8}$	3	8
S	008187	4x1 $\frac{1}{2}$	1 $\frac{3}{8}$	3 $\frac{1}{2}$	9

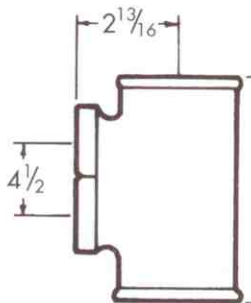

**DOUBLE VERTICAL
SAN TAP TEE**

Ship Code	UPCode 670610	Size	Wt.
S	008194	2x1 $\frac{1}{2}$	4.1

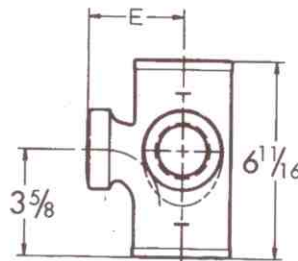

SAN TAP TEE
(w/Tap on Side)

Ship Code	UPCode 670610	Size	E	Wt.
S	008149	2x1 $\frac{1}{2}$ x1 $\frac{1}{2}$	2 $\frac{13}{16}$	3.8
S	008163	3x1 $\frac{1}{2}$ x1 $\frac{1}{2}$	3 $\frac{5}{16}$	4.7

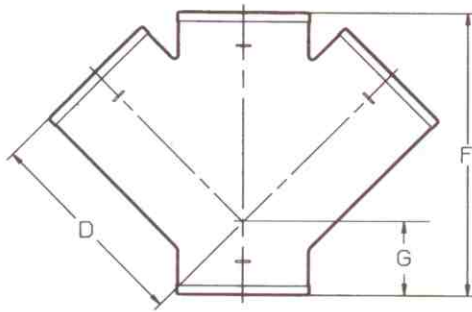

DOUBLE WYE

Ship Code	UPCode 670610	Size	D	F	G	Wt.
S	008538	2	4 ⁵ / ₈	6 ⁵ / ₈	2	3.6
S	008545	3x2	5 ⁵ / ₁₆	6 ⁵ / ₈	1 ¹ / ₂	6.2
S	008552	3	5 ³ / ₄	8	2 ¹ / ₄	6.5
S	008569	4x2	6	6 ⁵ / ₈	1	7.5
S	008576	4x3	6 ¹ / ₂	8	1 ¹¹ / ₁₆	8.5
S	008583	4	7 ¹ / ₁₆	9 ¹ / ₂	2 ⁷ / ₁₆	10.3
S	008590	5x4	8 ¹ / ₂	11 ³ / ₁₆	2 ⁷ / ₁₆	15.0
S	008606	6x4	9 ¹ / ₄	11 ³ / ₁₆	1 ¹⁵ / ₁₆	17.8
S	008613	6	10 ³ / ₄	14 ¹ / ₁₆	3 ⁵ / ₁₆	24.2
N	274445	8x4	10 ³ / ₈	11 ⁷ / ₁₆	1 ⁵ / ₁₆	23.0
S	383093	8x6	11 ¹³ / ₁₆	14 ³ / ₁₆	2 ⁵ / ₁₆	32.3
S	008620	8	13 ³ / ₈	17 ⁷ / ₈	3	50.0

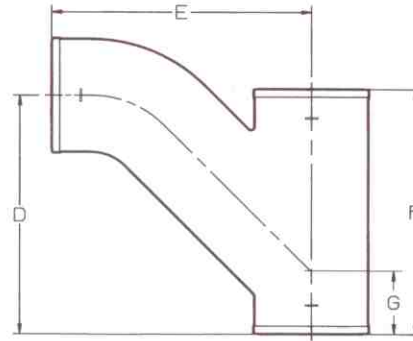

COMBINATION

Ship Code	UPCode 670610	Size	D	E	F	G	Wt.
S	008767	1 ¹ / ₂	4 ³ / ₄	5 ³ / ₈	6	2	2.6
S	008774	2x1 ¹ / ₂	5	5 ⁷ / ₈	6	2	2.8
S	008781	2	5 ³ / ₈	6 ⁷ / ₈	6 ⁵ / ₈	2	4.5
S	383062	3x1 ¹ / ₂	5 ¹ / ₂	6 ³ / ₄	6 ⁵ / ₈	1 ¹ / ₂	4.0
S	008798	3x2	5 ¹ / ₂	6 ³ / ₄	6 ⁵ / ₈	1 ¹ / ₂	5.8
S	008804	3	7 ⁵ / ₁₆	8	8	2 ¹ / ₄	8.4
S	008811	4x2	5 ¹ / ₂	7 ¹ / ₄	6 ⁵ / ₈	1	7.4
S	008828	4x3	7 ¹ / ₄	8 ¹ / ₂	8	1 ¹¹ / ₁₆	10.6
S	008835	4	9 ¹ / ₄	10	9 ¹ / ₂	2 ⁷ / ₁₆	14.5
S	008842	5x2	5 ¹⁵ / ₁₆	7 ³ / ₄	8 ¹ / ₁₆	1 ⁵ / ₁₆	8.0
S	008859	5x3	7 ³ / ₄	9	9 ¹¹ / ₁₆	1 ¹¹ / ₁₆	12.0
S	008866	5x4	9 ³ / ₄	10 ¹ / ₂	11 ³ / ₁₆	2 ⁷ / ₁₆	14.7
S	008873	5	11 ³ / ₄	12 ¹ / ₂	12 ⁵ / ₈	3 ³ / ₈	21.0
S	008880	6x2	6	8 ¹ / ₄	8 ⁵ / ₁₆	1/2	10.0
S	008897	6x3	7 ¹³ / ₁₆	9 ¹ / ₂	9 ³ / ₄	1 ¹ / ₄	12.5
S	008903	6x4	9 ³ / ₄	11	11 ³ / ₁₆	1 ¹⁵ / ₁₆	18.2
S	008910	6x5	11 ¹¹ / ₁₆	13	12 ¹ / ₂	2 ⁹ / ₁₆	23.0
S	008927	6	13 ⁵ / ₈	14 ³ / ₈	14 ¹ / ₁₆	3 ⁵ / ₁₆	30.1
S	008934	8x4	9 ⁷ / ₁₆	11 ⁵ / ₁₆	11 ³ / ₁₆	7/8	26.0
S	008941	8x6	12	13 ³ / ₈	13 ¹⁵ / ₁₆	2 ¹ / ₄	36.0
S	008958	8	14 ³ / ₄	15 ⁵ / ₁₆	16 ¹⁵ / ₁₆	3 ³ / ₄	50.0

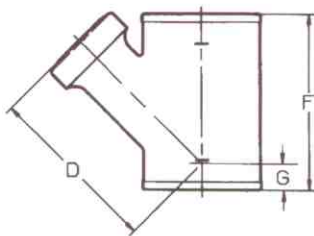

TAP WYE

Ship Code	UPCode 670610	Size	D	F	G	Wt.
S	008460	2x1 ¹ / ₂	5 ¹ / ₁₆	6 ⁵ / ₈	1 ⁵ / ₈	3.5
S	008477	2x2	5 ¹ / ₁₆	6 ⁵ / ₈	1 ⁵ / ₈	5.0
S	008484	3x1 ¹ / ₂	5 ³ / ₄	6 ⁵ / ₈	1 ¹ / ₂	3.5
S	008491	3x2	5 ¹³ / ₁₆	6 ⁵ / ₈	1 ¹ / ₂	4.3
S	008514	4x1 ¹ / ₂	6 ⁷ / ₁₆	6 ⁵ / ₈	1	5.7
S	008521	4x2	6 ¹ / ₂	6 ⁵ / ₈	1	6.0

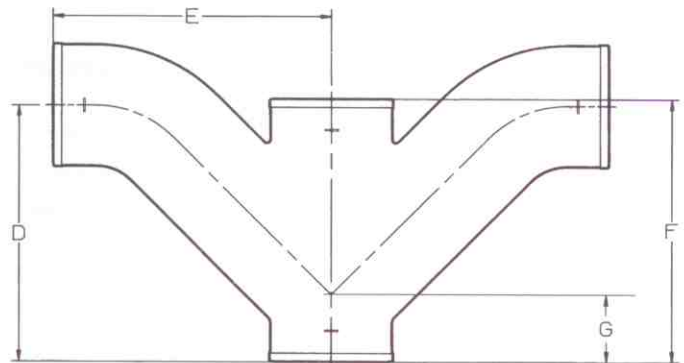

DOUBLE COMBINATION

Ship Code	UPCode 670610	Size	D	E	F	G	Wt.
S	009009	2	5 ³ / ₈	6 ⁷ / ₈	6 ⁵ / ₈	2	6.2
S	009016	3x2	5 ¹ / ₂	6 ³ / ₄	6 ⁵ / ₈	1 ¹ / ₂	7.2
S	009023	3	7 ⁵ / ₁₆	8	8	2 ¹ / ₄	9.9
S	009030	4x2	5 ¹ / ₂	7 ¹ / ₄	6 ⁵ / ₈	1	7.6
S	009047	4x3	7 ¹ / ₄	8 ¹ / ₂	8	1 ¹¹ / ₁₆	12.0
S	009054	4	9 ¹ / ₄	10	9 ¹ / ₂	2 ⁷ / ₁₆	17.7

SHIPPING CODE
S = From Stock
N = Non-Stock; Check in advance for availability.

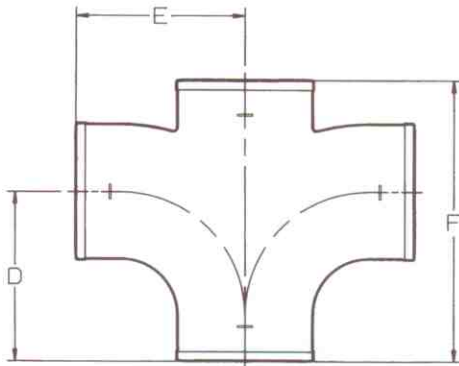

SAN CROSS

Ship Code	UPCode 670610	Size	D	E	F	Wt.
S	009061	1½	4¼	4¼	6½	3.1
S	009078	2	4½	4½	6¾	4.0
S	009085	3x2	4½	5	6¾	6.1
S	009092	3	5	5	8	6.2
S	009108	4x2	4½	5½	6¾	6.2
S	009115	4x3	5	5½	8	9.7
S	009122	4	5½	5½	9⅞	8.9
S	009139	5x4	6	6	10⅞	13.3
S	009146	6x4	6	6½	10⅞	12.0
S	009153	6	7	7	12½	20.3
S	009160	8x4	6½	7½	11½	25.0
S	389866	8	8½	8½	15½	38.8

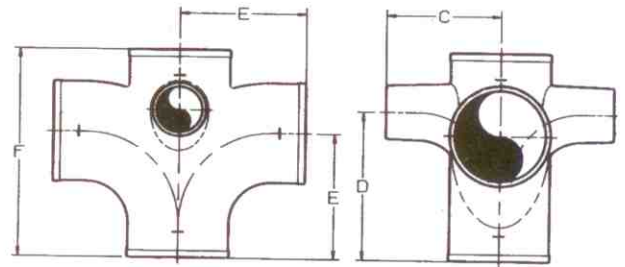

**SAN CROSS
(w/2" 90° Opening Above Center)
New Orleans Code
(No Baffle)**

Ship Code	UPCode 670610	Size (Inlets)	C	D	E	F	Wt.
S	009221	3 (2)	4½	6	5	8¾	9.3
S	009238	4 (1)	5	6½	5½	9⅞	11.0
S	009245	4 (2)	5	6½	5½	9⅞	12.0

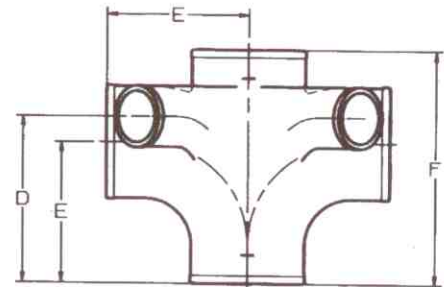
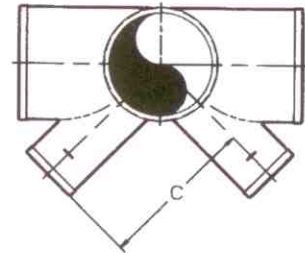

**SAN CROSS
(with two 2" 45° San Openings—Same Side)
New Orleans Code
(No Baffle)**

Ship Code	UPCode 670610	Size	C	D	E	F	Wt.
S	009252	3	5⅞	6	5	8	7.6
S	009269	4	6⅞	6½	5½	9⅞	11.0

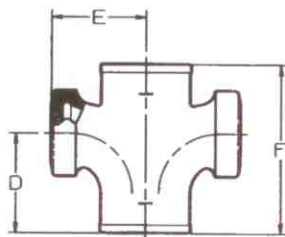

**SAN TAP CROSS
(No Baffle)**

Ship Code	UPCode 670610	Size	D	E	F	Wt.
S	009283	1½x1½	3¼	2⅞	5⅞	3.4
S	009290	2x1¼	3¼	2⅞	5⅞	3.7
S	009306	2x1½	3¼	2⅞	5⅞	3.5
S	009313	2x2	3¼	3⅞	6⅞	4.0
S	009337	3x1½	3¼	3⅞	5⅞	4.6
S	009344	3x2	3¼	3⅞	6⅞	5.0
S	009368	4x1½	3¼	3⅞	5⅞	5.5
S	009375	4x2	3¼	4⅞	6⅞	6.7
S	009405	5x1½	3⅞	4⅞	6⅞	8.4
N	009382	6x1½	3¼	4⅞	6⅞	10.5

SHIPPING CODE
S = From Stock
N = Non-Stock; Check in advance for availability.



NO-HUB ASA Group 022 TEES, FERRULES, REDUCERS, ADAPTERS & PLUGS

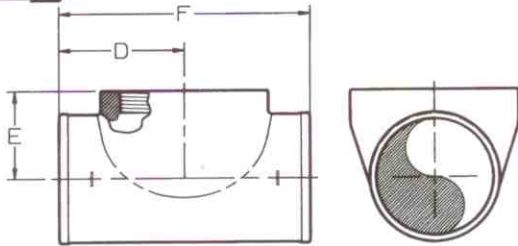

**TEST TEE
(Less Plug)**

Ship Code	UPCode 670610	Size-IPS	E	F	D	Wt.
S	009429	2-2	2	6 ³ / ₈	3 ³ / ₁₆	2.7
S	009436	3-3	2 1 ¹ / ₁₆	7 ³ / ₄	3 ⁷ / ₈	4.8
S	009443	4-4	3	8 ⁷ / ₈	4 ⁷ / ₁₆	9.4
S	009450	5-5	4 ¹ / ₂	11 ¹ / ₂	5 ³ / ₄	14.7
S	009467	6-6	5	12 ¹ / ₂	6 ¹ / ₄	18.4
S	009474	8-8	6	15 ¹ / ₄	7 ⁵ / ₈	30.4
S	381501	10-10	6 ¹ / ₂	20	10	59.0

**TEST TEE
(w/ Type A Plug)**

Ship Code	UPCode 670610	Size-IPS	E	F	D	Wt.
S	011736	2-2	2	6 ³ / ₈	3 ³ / ₁₆	3.0
S	011743	3-3	2 1 ¹ / ₁₆	7 ³ / ₄	3 ⁷ / ₈	5.5
S	011750	4-4	3	8 ⁷ / ₈	4 ⁷ / ₁₆	10.4
S	011767	5-5	4 ¹ / ₂	11 ¹ / ₂	5 ³ / ₄	16.0
S	011774	6-6	5	12 ¹ / ₂	6 ¹ / ₄	20.7
S	011781	8-8	6	15 ¹ / ₄	7 ⁵ / ₈	36.0

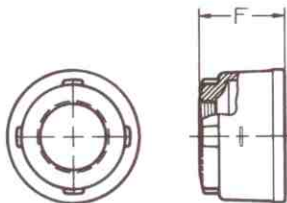

**FERRULE
Less Plug**

Ship Code	UPCode 671610	Size-IPS	F	Wt.
S	009979	2-1 ¹ / ₂	1 ³ / ₄	0.4
S	009986	3-2 ¹ / ₂	1 ³ / ₄	0.9
S	009993	4-3 ¹ / ₂	1 ³ / ₄	1.1
S	010005	5-4	3 ³ / ₈	5.0
S	010012	6-5	3 ³ / ₃₂	6.0
S	010029	8-6	3 ³ / ₃₂	7.8

**FERRULE
w/ Type A Plug**

Ship Code	UPCode 671610	Size	F	Wt.
S	012108	2x1 ¹ / ₂	1 ³ / ₄	0.6
S	012115	3x2 ¹ / ₂	1 ³ / ₄	1.3
S	012122	4x3 ¹ / ₂	1 ³ / ₄	1.9
S	012139	5x4	3 ³ / ₈	6.0
S	012146	6x5	3 ³ / ₃₂	7.3
S	012153	8x6	3 ³ / ₃₂	10.1

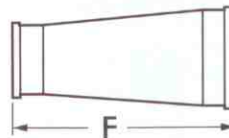

INCREASER-REDUCER

Ship Code	UPCode 671610	Size	F	Wt.
S	009658	3x4	8	4.6

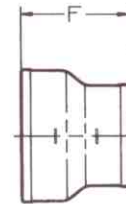

SHORT REDUCER

Ship Code	UPCode 670610	Size	F	Wt.
S	009665	2x1 ¹ / ₂	3 ⁵ / ₈	1.1
S	382607	3x1 ¹ / ₂	3 ⁵ / ₈	1.7
S	009672	3x2	3 ⁵ / ₈	1.4
S	009689	4x2	3 ⁵ / ₈	2.2
S	009696	4x3	3 ⁵ / ₈	2.2
S	383314	5x2	4	3.3
S	009702	5x3	4	3.7
S	009719	5x4	4	3.6
S	009726	6x2	4	4.3
S	009733	6x3	4	3.8
S	009740	6x4	4	4.2
S	009757	6x5	4 ¹ / ₂	5.0
S	009764	8x2	4 ¹ / ₂	8.0
S	009771	8x3	4 ¹ / ₂	7.5
S	009788	8x4	4 ¹ / ₂	7.6
S	009795	8x5	5	8.6
S	009801	8x6	5	7.5
S	009818	10x4	5 ¹ / ₂	15.0
S	009825	10x6	6	14.3
S	009832	10x8	6	13.0
S	377559	12x4	6 ¹ / ₂	20.0
S	376507	12x6	6 ¹ / ₂	20.0
S	376514	12x8	7	21.0
S	376521	12x10	7 ¹ / ₂	25.0
S	377566	15x4	7	32.0
S	376750	15x6	7	35.0
S	376538	15x8	7	34.0
S	376545	15x10	7 ¹ / ₂	38.0
S	376552	15x12	7 ³ / ₄	37.0

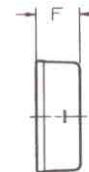

BLIND PLUG

Ship Code	UPCode 670610	Size	F	Wt.
S	010036	1 ¹ / ₂	1 ³ / ₄	0.8
S	010043	2	1 ³ / ₄	0.7
S	010050	3	1 ³ / ₄	1.2
S	010067	4	1 ³ / ₄	2.0
S	010074	5	1 ³ / ₄	2.5
S	010081	6	1 ³ / ₄	3.0
S	010098	8	2 ¹ / ₄	6.7
S	010104	10	3	15.5
S	377535	12	3 ¹ / ₂	18.0
S	377542	15	3 ¹ / ₂	33.0

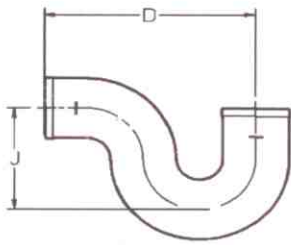

P-TRAP

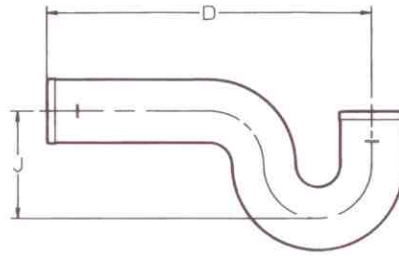

LONG P-TRAP

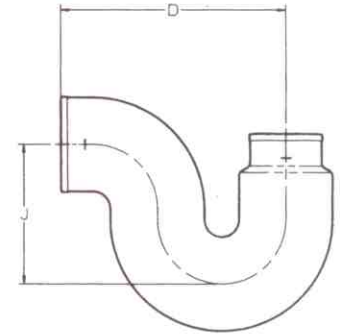

REDUCING P-TRAP

Ship Code	UPCode 670610	Size	D	J	Wt.
S	010111	1½	6¾	3½	2.8
S	010128	2	7½	4	4.7
S	010135	3	9	5½	9.7
S	010142	4	10½	6½	14.8
S	010159	6	14	8½	33.0

Ship Code	UPCode 670610	Size	D	J	Wt.
S	010166	2x12	12	4	5.8
S	010173	2x14	14	4	6.7
S	010180	2x16	16	4	7.6
S	010197	2x18	18	4	8.5

Ship Code	UPCode 670610	Size	D	J	Wt.
S	011231	3x2	9	5½	

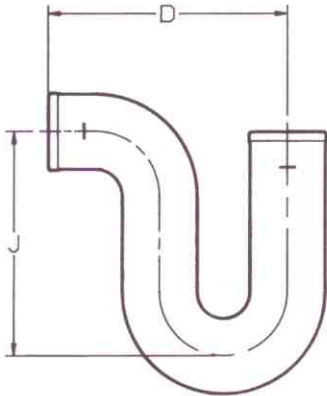

DEEP SEAL P-TRAP

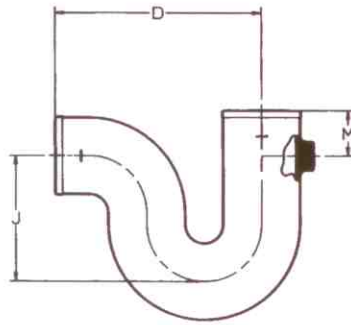

P-TRAP w/½" Primer Tap

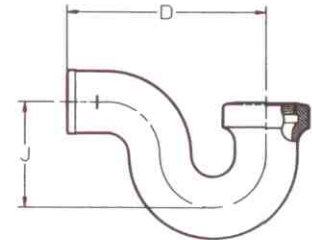

TAP P-TRAP

Ship Code	UPCode 670610	Size	D	J	Wt.
S	010258	2	7½	7	6.5
S	010265	3	9	7	10.4
S	010272	4	10½	8	17.2

Ship Code	UPCode 670610	Size	D	M	J	Wt.
S	011200	2	7½	2	4	5.7
S	011217	3	9	2	5½	8.9
S	011224	4	10½	2	6½	16.6

Ship Code	UPCode 670610	Size	D	J	Wt.
S	010340	1½	6¾	3½	3.8
S	010364	2x1½	7½	4	5.0
S	010371	2	7½	4	4.1

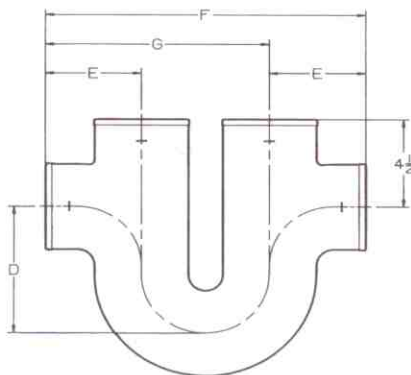

RUNNING TRAP w/TWO 4" VENTS

Ship Code	UPCode 670610	Size	D	E	F	G	Wt.
S	010296	4	6½	4½	15	10½	27.0

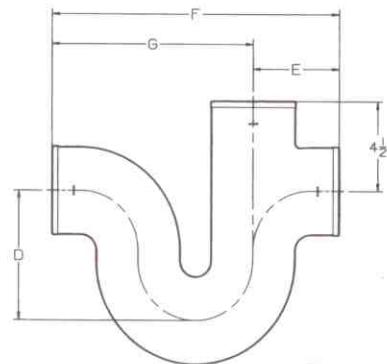

RUNNING TRAP w/4" SINGLE VENT

Ship Code	UPCode 670610	Size	D	E	F	G	Wt.
S	010289	4	6½	4½	15	10½	20.0

***457-4" Stack, 4" Closet Waste, 2" Vent**
***458-4" Stack, 4" Closet Waste, 2" Waste, 2" Vent**

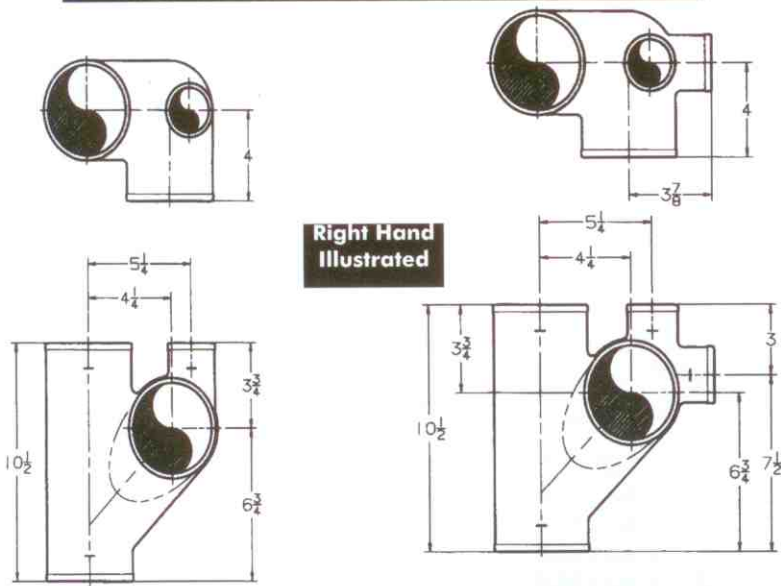

**Right Hand
Illustrated**

***9-457 VENTED CLOSET TEE
w/2" Top Vent**

Ship Code	UPCode 670610	Size	Wt.
S	010470	4x4x2x4(R)	12.5
S	010487	4x4x2x4(L)	12.5

**9-458 VENTED CLOSET TEE
w/2" Top Vent
and 2" Side Openings**

Ship Code	UPCode 670610	Size	Wt.
S	010494	4x4x2x2x4(R)	12.8
S	010500	4x4x2x2x4(L)	12.8

***399-4" Stack, two 4" Closet
Waste, two 2" Waste, 3" Vent**

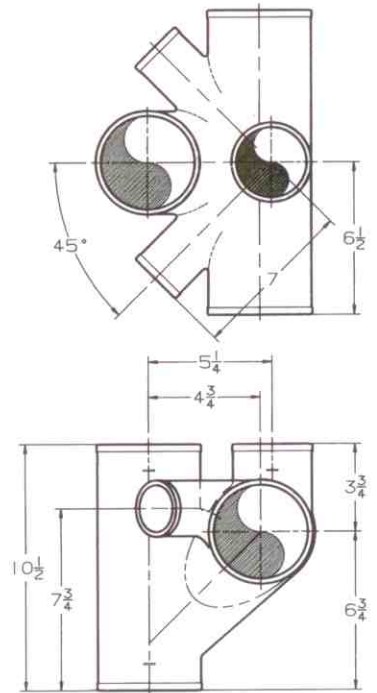

***9-399 VENTED
CLOSET CROSS
(No Baffle)**

Ship Code	UPCode 670610	Size	Wt.
S	010456	*4x3x2x4	20.0

***463-4" Stack, two 4"Waste, 2" Vent**
***464-4" Stack, two 4" Waste, 2" Waste, 2" Vent**

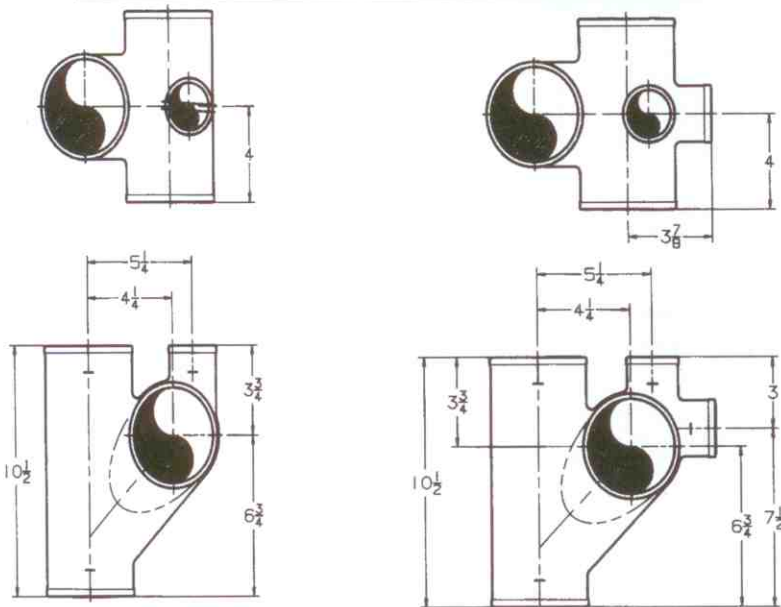

***9-463 VENTED CLOSET CROSS
w/2" Top Vent (With Baffle)**

Ship Code	UPCode 670610	Size	Wt.
S	010517	4x4x2x4x4	13.5

***9-464 VENTED CLOSET CROSS
w/2" Top Vent and 2" Side Opening
(No Baffle)**

Ship Code	UPCode 670610	Size	Wt.
S	010531	4x4x2x2x4x4	13.8

*** NOTE:
PRODUCTS
ON THIS
PAGE ARE
NOT LISTED
BY I.A.P.M.O.**